



Tension Pins

Light Duty Execution
DIN EN ISO 13337
Heavy Duty Execution
DIN EN ISO 8752
Heavy Duty Execution
DIN EN ISO 8752
stainless steel



Coiled Spring Pins

Standard Execution
DIN EN ISO 8750
Standard Execution
DIN EN ISO 8750
stainless steel
Heavy Duty Execution
DIN EN ISO 8748

Tension Pins (slotted)

Coiled Spring Pins

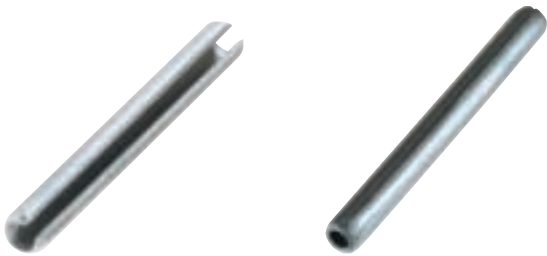

Production Program covers the range of Tension Pins / Coiled Spring Pins per DIN EN ISO

- | | |
|------------------------|--|
| - Light duty execution | Tension Pins (slotted) per DIN EN ISO 13337 |
| - Standard execution | Coiled Spring Pins per DIN EN ISO 8750 |
| - Heavy duty execution | Tension Pins (slotted) per DIN EN ISO 8752
Coiled Spring Pins per DIN EN ISO 8748 |

Material

- Spring Steel / High Carbon Steel
- Austenitic chrome-nickel stainless steel

Dimensions

- Nominal dia. 1 mm - 50 mm
- Length 4 mm - 200 mm

Special Production

- Plated execution
- Special executions to avoid interlocking
- Special materials
- Special sizes

Assortment Boxes

- Customer logo upon request

Jörg Vogelsang
Your Partner for Tension Pins and Coiled Spring Pins

Insertion and removal

Spring pins employ a chamfered end to facilitate line-up and insertion. Typical insertion techniques are tap-in with hammer, or press-in using air or hydraulic press.

The nominal pin diameter size should be equal to the nominal recommended hole size (drill size).

Pins for high-volume, automatic insertion applications can be provided with "compressed" tapers and slot designs which prevent interlocking.

nominal diameter*	above	1	3	6	10	18	30
	up to	3	6	10	18	30	50
tolerances		+0.10	+0.12	+0.15	+0.18	+0.21	+0.25

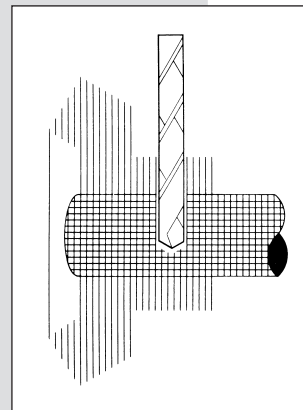

Drill hole

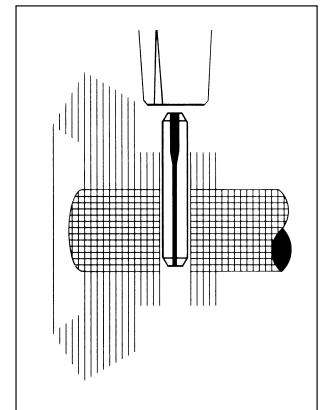

Press or tape in place

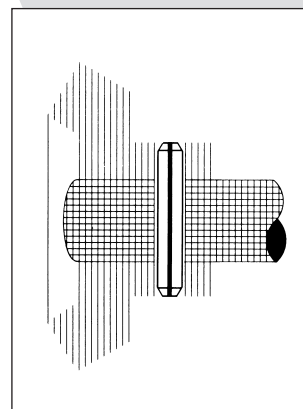

Inserted pin

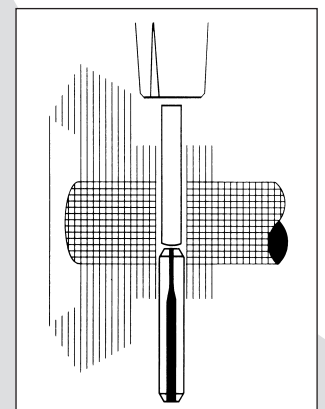

Tap out with hammer and drift

Examples of application

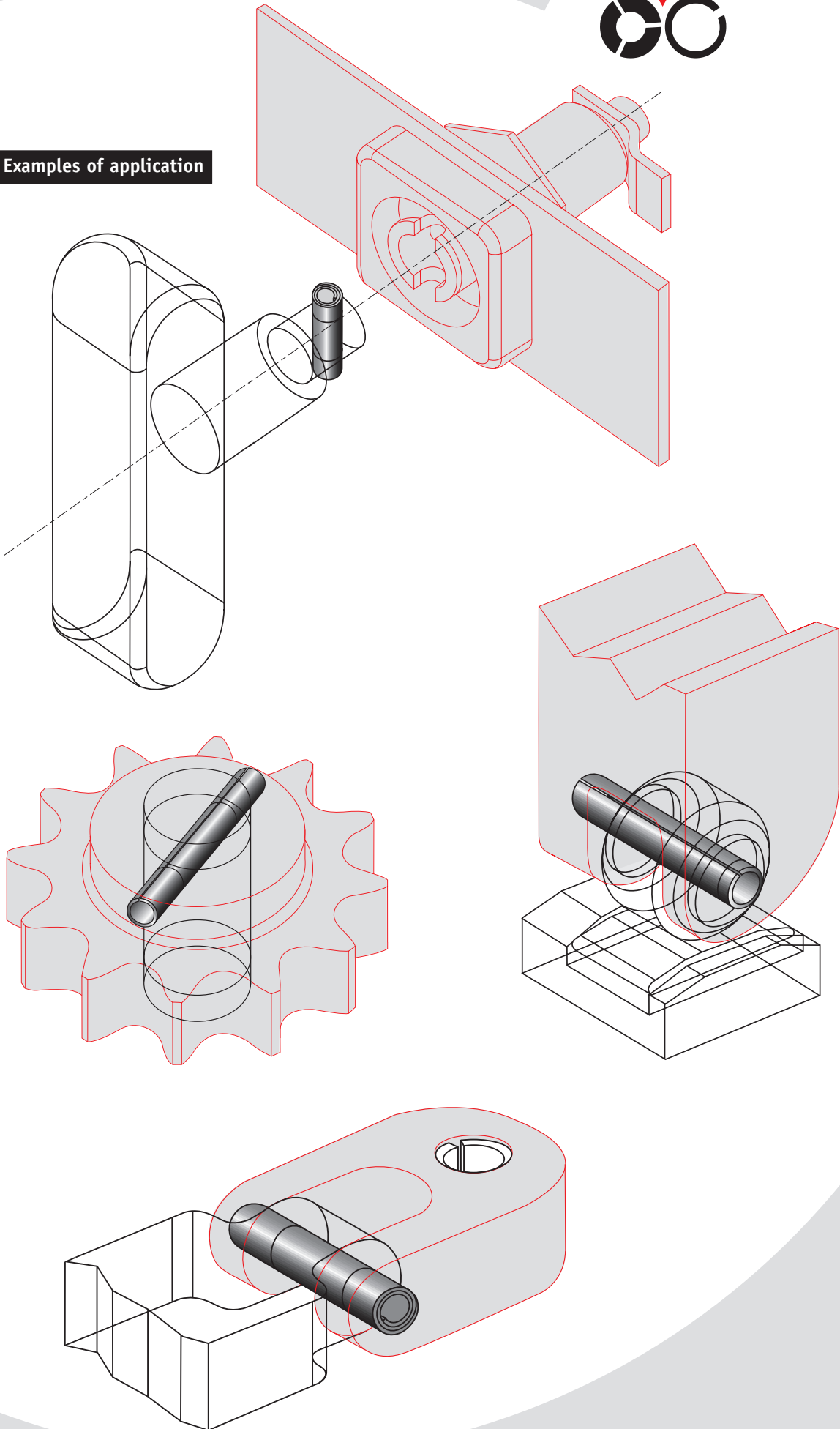

**DIN EN ISO 8752 spring pin
(heavy duty)**

Dimensions and
designation up to 8 mm
nominal diameter

Designation of a spring pin
with 10 mm nominal
diameter and length
 $l = 40$ mm:

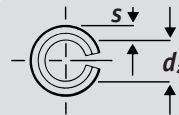
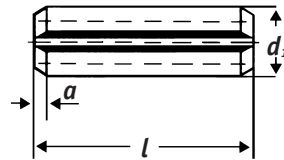

**DIN EN ISO 8752
spring pin – 10 x 40**

Nominal diameter*		1	1,5	2	2,5	3	3,5	4	4,5	5	6	8	10	
DIN EN ISO 8752	Before installation	a — max.	0.35	0.45	0.55	0.6	0.7	0.8	0.85	1.0	1.1	1.4	2.0	2.4
		a — min.	0.15	0.25	0.35	0.4	0.5	0.6	0.65	0.8	0.9	1.2	1.6	2.0
	d_1 — max.	1.3	1.8	2.4	2.9	3.5	4.0	4.6	5.1	5.6	6.7	8.8	10.8	
	d_1 — min.	1.2	1.7	2.3	2.8	3.3	3.8	4.4	4.9	5.4	6.4	8.5	10.5	
	d_2 \approx	0.8	1.1	1.5	1.8	2.1	2.3	2.8	2.9	3.4	4.0	5.5	6.5	
Shear force**, (double-shear²) kN		0.2	0.3	0.4	0.5	0.6	0.75	0.8	1.0	1.0	1.2	1.5	2.0	
+/- 0.25	4	0.015	0.034	0.061	0.095	0.136	0.197	0.239						
	5	0.019	0.043	0.077	0.118	0.170	0.246	0.299	0.397	0.471				
	6	0.023	0.051	0.092	0.142	0.204	0.296	0.358	0.476	0.566				
	8	0.031	0.068	0.122	0.182	0.272	0.394	0.478	0.635	0.754				
	10	0.038	0.085	0.153	0.236	0.340	0.493	0.597	0.793	0.942	1.32	2.24	3.69	
+/- 0.5	12	0.045	0.103	0.184	0.283	0.407	0.591	0.716	0.952	1.13	1.59	2.66	4.43	
	14	0.052	0.120	0.214	0.330	0.475	0.689	0.836	1.11	1.32	1.86	3.13	5.17	
	16	0.059	0.137	0.244	0.377	0.543	0.788	0.955	1.27	1.51	2.12	3.58	5.90	
	18	0.067	0.154	0.275	0.424	0.611	0.886	1.07	1.43	1.70	2.39	4.03	6.64	
	20	0.076	0.171	0.305	0.471	0.679	0.985	1.19	1.59	1.88	2.65	4.48	7.38	
	22			0.336	0.519	0.746	1.08	1.31	1.75	2.07	2.92	4.92	8.12	
	24			0.367	0.565	0.814	1.18	1.43	1.90	2.26	3.19	5.37	8.86	
	26			0.397	0.613	0.882	1.28	1.55	2.06	2.45	3.46	5.82	9.59	
	28			0.427	0.660	0.950	1.38	1.67	2.22	2.64	3.72	6.26	10.3	
	30			0.458	0.707	1.02	1.48	1.79	2.38	2.83	3.98	6.71	11.1	
	32					1.09	1.58	1.91	2.54	3.02	4.25	7.16	11.8	
	36					1.22	1.77	2.18	2.66	3.39	4.78	8.06	13.3	
	40					1.36	1.97	2.39	3.17	3.77	5.32	8.95	14.8	
	45							2.68	3.57	4.24	5.98	10.1	16.6	
	50							2.98	3.96	4.71	6.64	11.2	18.4	
+/- 0.75	55								5.18	7.31	12.3	20.3		
	60								5.65	7.97	13.4	22.1		
	65								6.12	8.63	14.5	24.0		
	70								6.59	9.30	15.7	25.8		
	75								7.06	9.98	16.8	27.7		
	80								7.54	10.7	18.0	29.5		
	85									11.3	19.0	31.4		
	90									12.0	20.1	33.2		
	95									12.6	21.3	35.0		
	100									13.3	22.4	36.9		
	120										26.8	44.3		
	140											51.7		
	160											59.0		
	180													
	200													
Deviation allowed		length l		Weight (7.85 kg/dm³) kg/per 1000 \approx										

Dimensions and designation, 8 mm nominal diameter and above

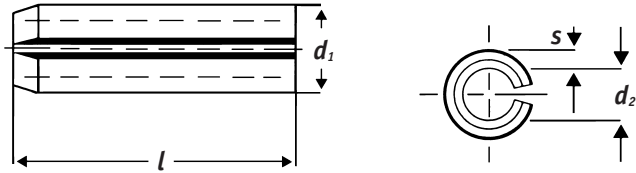

* The nominal diameter of the spring pin is identical to the nominal diameter of the corresponding seating hole, for which tolerance field H 12 is specified.

** Each individual case must be examined to determine whether, on the basis of physical circumstances, these shear forces need to be taken into account.

	12	13	14	16	18	20	21	25	28	30	32	35	38	40	45	50
	2.4	2.4	2.4	2.4	2.4	3.4	3.4	3.4	3.4	3.4	3.6	3.6	4.6	4.6	4.6	4.6
	2.0	2.0	2.0	2.0	2.0	3.0	3.0	3.0	3.0	3.0	3.0	3.0	4.0	4.0	4.0	4.0
	12.8	13.8	14.8	16.8	18.9	20.9	21.9	25.9	28.9	30.9	32.9	35.9	38.9	40.9	45.9	50.9
	12.5	13.5	14.5	16.5	18.5	20.5	21.5	25.5	28.5	30.5	32.5	35.5	38.5	40.5	45.5	50.5
	7.5	8.5	8.5	10.5	11.5	12.5	13.5	15.5	17.5	18.5	20.5	21.5	23.5	25.5	28.5	31.5
	2.5	2.5	3.0	3.0	3.5	4.0	4.0	5.0	5.5	6.0	6.0	7.0	7.5	7.5	8.5	9.5
	104.1	115.1	144.7	171	222.5	280.6	298.2	438.5	542.6	631.4	684	859	1003	1068	1360	1685
	5.55	6.18	7.80	9.19	12.9	15.3										
	6.66	7.42	9.35	11.0	14.5	18.4										
	7.78	8.66	10.9	12.9	16.9	21.4	22.8	33.4	41.5	48.5						
	8.89	9.90	12.5	14.7	19.3	24.5	26.0	38.2	47.4	55.4						
	10.0	11.1	14.0	16.5	21.8	27.5	29.3	43.0	53.3	62.3						
	11.1	12.4	15.6	18.4	24.2	30.8	32.5	47.8	59.2	69.2	75.1	94	110	117	150	186
	12.2	13.6	17.1	20.2	26.6	33.6	35.8	52.5	65.2	76.2	82.6	103	121	129	165	205
	13.3	14.8	18.7	22.0	29.0	36.7	39.0	57.3	71.1	83.1	90.1	113	132	141	180	223
	14.4	16.1	20.3	23.9	31.4	39.8	42.3	62.0	77.0	90.0	97.6	122	143	153	195	242
	15.6	17.3	21.8	25.7	33.8	42.8	45.5	66.8	82.9	96.9	105	132	154	164	210	261
	16.7	18.5	23.4	27.6	36.3	45.9	48.8	71.6	88.6	104	113	141	165	176	225	279
	17.8	19.8	24.9	29.4	38.7	48.9	52.0	76.4	94.8	111	120	150	176	188	240	298
	20.0	22.3	28.1	33.1	43.5	55.1	58.6	85.9	107	125	135	169	198	211	270	335
	22.2	24.7	31.2	36.7	48.4	61.2	65.1	95.5	118	138	150	188	220	235	300	372
	25.0	27.8	35.1	41.3	54.4	68.8	73.2	107	133	156	169	211	248	264	337	419
	27.8	30.9	39.0	45.9	60.4	76.5	81.3	119	148	173	188	235	276	293	375	465
	30.5	34.0	42.9	50.5	66.5	84.1	89.5	131	163	190	206	258	303	323	412	512
	33.3	37.1	46.8	55.1	72.5	91.8	97.6	143	178	208	225	282	331	352	450	558
	36.1	40.2	50.1	59.7	78.6	99.4	106	155	193	225	244	305	358	382	487	605
	38.9	43.3	54.6	64.3	84.6	107	114	167	207	242	263	329	386	411	525	651
	41.7	46.4	58.5	68.9	90.7	115	122	179	222	260	282	352	413	440	562	698
	44.4	49.5	62.4	73.5	96.7	122	130	191	237	277	300	376	441	470	599	745
	47.2	52.5	66.3	78.1	103	130	138	203	252	294	319	399	468	499	637	791
	50.0	55.6	70.2	82.7	109	138	146	215	267	312	338	422	496	528	674	838
	52.8	58.7	74.1	87.3	115	145	155	227	281	329	357	446	524	558	712	884
	55.5	61.8	77.9	91.9	121	153	163	239	296	346	375	470	551	587	749	931
	66.6	74.2	93.5	110	145	184	195	286	355	415	450	564	661	704	899	1120
	77.8	86.5	109	129	169	214	228	334	415	485	526	658	771	821	1050	1300
	88.9	98.9	125	147	193	245	260	382	474	554	601	752	882	939	1200	1490
	100	111	140	165	218	275	293	430	533	623	676	846	992	1060	1350	1680
			155	184	241	306	325	477	592	692	751	940	1100	1170	1500	1860

**DIN EN ISO 13337 spring pin
(light duty)**

Dimensions and
designation up to 8 mm
nominal diameter

Designation of a spring pin
with 10 mm nominal
diameter and length
 $l = 40$ mm:

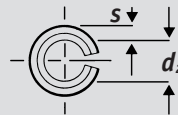
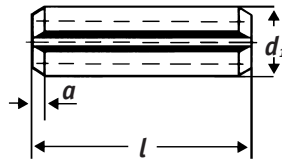

**DIN EN ISO 13337
spring pin – 10 x 40**

Nominal diameter*		2	2,5	3	3,5	4	4,5	5	6	8	10
DIN EN ISO 13337 Before installation	a — max.	0.4	0.45	0.45	0.5	0.7	0.7	0.7	0.9	1.8	2.4
	— min.	0.2	0.25	0.25	0.3	0.5	0.5	0.5	0.7	1.5	2.0
	d_1 — max.	2.4	2.9	3.5	4.0	4.6	5.1	5.6	6.7	8.8	10.8
	— min.	2.3	2.8	3.3	3.8	4.4	4.9	5.4	6.4	8.5	10.5
	d_2 \approx	1.9	2.3	2.7	3.1	3.4	3.9	4.4	4.9	7.0	8.5
Shear force**, (double-shear²) kN		1.5	2.4	3.5	4.6	8.0	8.8	10.4	18	24	40
+/- 0.25	4	0.034	0.054	0.078	0.106	0.168	0.193				
	5	0.043	0.067	0.097	0.132	0.210	0.241	0.271			
	6	0.051	0.080	0.116	0.159	0.252	0.289	0.325			
	8	0.068	0.107	0.155	0.212	0.336	0.385	0.433			
	10	0.085	0.134	0.193	0.264	0.420	0.481	0.541	0.93	1.30	2.14
+/- 0.5	12	0.102	0.161	0.232	0.317	0.504	0.578	0.650	1.12	1.55	2.57
	14	0.119	0.187	0.271	0.370	0.588	0.674	0.758	1.30	1.81	3.00
	16	0.136	0.214	0.309	0.423	0.672	0.770	0.866	1.49	2.07	3.43
	18	0.153	0.241	0.348	0.476	0.756	0.866	0.974	1.67	2.33	3.86
	20	0.170	0.267	0.386	0.528	0.840	0.962	1.08	1.86	2.59	4.29
	22	0.187	0.294	0.425	0.581	0.924	1.06	1.19	2.05	2.85	4.72
	24	0.204	0.321	0.464	0.634	1.01	1.16	1.30	2.23	3.11	5.14
	26	0.221	0.347	0.502	0.687	1.09	1.25	1.41	2.42	3.37	5.57
	28	0.238	0.374	0.541	0.740	1.18	1.35	1.52	2.60	3.63	6.00
	30	0.255	0.400	0.579	0.792	1.26	1.44	1.62	2.79	3.88	6.43
	32			0.618	0.845	1.34	1.54	1.73	2.98	4.14	6.86
	36			0.695	0.951	1.51	1.73	1.95	3.49	4.66	7.72
	40			0.772	1.060	1.68	1.92	2.16	3.72	5.18	8.57
	45					1.89	2.16	2.44	4.18	5.83	9.64
	50					2.10	2.40	2.70	4.65	6.48	10.7
+/- 0.75	55							2.98	5.12	7.12	11.8
	60							3.25	5.58	7.77	12.9
	65							3.79	6.04	8.42	13.9
	70							4.06	6.51	9.06	15.0
	75							4.33	6.98	9.71	16.1
	80								7.44	10.4	17.1
	85								7.90	11.0	18.2
	90								8.37	11.7	19.3
	95								8.84	12.3	20.4
	100								9.30	13.0	21.4
	120									15.5	25.7
	140										30.0
	160										34.3
	180										
	200										
Deviation allowed		length l			Weight (7.85 kg/dm³) kg/per 1000 \approx						

Dimensions and designation, 8 mm nominal diameter and above

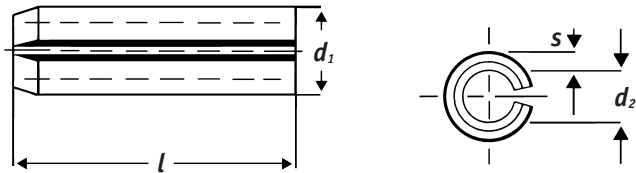

* The nominal diameter of the spring pin is identical to the nominal diameter of the corresponding seating hole, for which tolerance field H 12 is specified.

** Each individual case must be examined to determine whether, on the basis of physical circumstances, these shear forces need to be taken into account.

	12	13	14	16	18	20	21	25	28	30	35	40	45	50
	2.4	2.4	2.4	2.4	2.4	2.4	2.4	3.4	3.4	3.4	3.6	4.6	4.6	4.6
	2.0	2.0	2.0	2.0	2.0	2.0	2.0	3.0	3.0	3.0	3.0	4.0	4.0	4.0
	12.8	13.8	14.8	16.8	18.9	20.9	21.9	25.9	28.9	30.9	35.9	40.9	45.9	50.9
	12.5	13.5	14.5	16.5	18.5	20.5	21.5	25.5	28.5	30.5	35.5	40.5	45.5	50.5
	10.5	11.0	11.5	13.5	15.0	16.5	17.5	21.5	23.5	25.5	28.5	32.5	37.5	40.5
	1.0	1.2	1.5	1.5	1.7	2.0	2.0	2.0	2.5	2.5	3.5	4.0	4.0	5.0
	48	66	84	98	126	158	168	202	280	302	490	634	720	1000
	2.63	3.37	4.48	5.20	6.61	8.64								
	3.16	4.05	5.37	6.25	7.95	10.4								
	3.68	4.72	6.27	7.29	9.26	12.1	12.8	15.4	21.6	23.3				
	4.21	5.40	7.16	8.33	10.6	13.8	14.6	17.6	24.6	26.6				
	4.74	6.07	8.06	9.37	12.0	15.5	16.4	19.8	27.7	29.9				
	5.26	6.75	8.95	10.4	13.2	17.3	18.2	22.0	30.8	33.2	53.4	69.9	79.1	109
	5.79	7.42	9.85	11.4	14.6	19.0	20.1	24.2	33.9	36.6	58.8	76.9	87.0	120
	6.31	8.09	10.7	12.5	15.9	20.7	21.9	26.4	37.0	39.9	64.1	83.9	94.9	131
	6.84	8.76	11.6	13.5	17.2	22.5	23.7	28.6	40.1	43.2	69.4	90.9	103	142
	7.36	9.45	12.5	14.6	18.6	24.2	25.5	30.8	43.1	46.5	74.8	97.9	111	153
	7.89	10.1	13.4	15.6	19.8	25.9	27.4	33.0	46.2	49.9	80.1	105	119	164
	8.42	10.8	14.3	16.7	21.2	27.6	29.2	35.2	49.3	53.3	85.5	112	127	174
	9.47	12.1	16.1	18.7	23.8	31.1	32.8	39.6	55.5	59.8	96.1	126	142	196
	10.5	13.5	17.9	20.8	26.5	34.5	36.5	43.9	61.6	66.5	107	140	158	218
	11.8	15.2	20.1	23.4	29.8	38.8	41.0	49.5	69.3	74.8	120	157	178	245
	13.2	16.9	22.4	26.0	33.1	43.2	45.0	55.0	77.0	83.1	134	175	198	273
	14.5	18.5	24.6	28.6	36.4	47.5	50.2	60.4	84.8	91.4	147	192	217	300
	15.8	20.3	26.8	31.2	39.7	51.8	54.7	65.9	92.4	99.7	160	210	237	327
	17.1	21.9	29.1	33.8	43.0	56.1	59.3	71.4	100	108	174	227	257	354
	18.4	23.6	31.3	36.4	46.3	60.4	63.8	76.9	108	116	187	245	277	382
	19.7	25.3	33.6	39.0	49.6	64.8	68.4	82.4	115	125	200	262	296	409
	21.0	27.0	35.8	41.6	52.9	69.1	73.0	87.9	123	133	214	280	316	436
	22.4	28.7	38.0	44.2	56.3	73.4	77.5	93.4	131	141	227	297	336	463
	23.7	30.3	40.3	46.8	59.6	77.7	82.1	98.9	139	150	240	315	356	491
	25.0	32.1	42.5	49.4	62.9	82.0	86.0	104	146	158	254	332	376	518
	26.3	33.7	44.8	52.0	66.2	86.3	91.2	110	154	166	267	349	395	545
	31.6	40.5	57.3	62.5	79.5	104	109	132	185	199	320	419	474	654
	36.8	47.2	62.6	72.9	95.7	121	128	154	216	233	374	489	553	763
	42.1	54.0	71.6	83.3	106	138	146	176	246	266	427	559	633	872
	47.4	60.7	80.6	93.7	119	155	164	198	277	299	481	629	712	981
			89.6	104	132	173	182	220	308	332	534	699	791	1090

Coiled springs pins DIN EN ISO 8750 (normal duty)

Designation of a coiled spring pin with 10 mm nominal diameter and length $l = 40$ mm in normal duty, made from steel:

DIN EN ISO 8750 spring pin – 10 x 40 – ST

Designation of a coiled spring pin with 10 mm nominal diameter and length $l = 40$ mm in normal duty, made from stainless steel:

DIN EN ISO 8750 spring pin – 10 x 40 – A

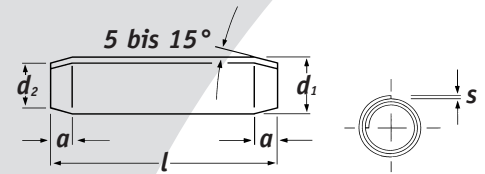

Nominal diameter ¹⁾		2	2,5	3	3,5	4	5	6	8	10	12	14	16	20	
DIN EN ISO 8750	Before installation	d_1 min.	2.13	2.65	3.15	3.67	4.20	5.25	6.25	8.30	10.35	12.40	14.45	16.45	20.40
		d_1 max.	2.25	2.78	3.30	3.84	4.40	5.50	6.50	8.63	10.80	12.85	14.95	17.00	21.00
		d_2 max.	1.90	2.40	2.90	3.40	3.90	4.85	5.85	7.80	9.75	11.70	13.60	15.60	19.60
		$a \approx$	0.70	0.70	0.90	1.00	1.10	1.30	1.50	2.00	2.50	3.00	3.50	4.00	4.50
		s	0.17	0.21	0.25	0.29	0.33	0.42	0.50	0.67	0.84	1.00	1.20	1.30	1.70
	Shear force ²⁾	kN ³⁾	2.50	3.90	5.50	7.50	9.60	15	22	39	62	89	120	155	250
	double-shear	kN ⁴⁾	1.90	2.90	4.20	5.70	7.60	11.50	16.8	30					
+/- 0.25	4	0.06													
	5	0.08	0.12												
	6	0.09	0.14	0.20	0.27										
	8	0.12	0.19	0.27	0.36	0.48									
	10	0.16	0.23	0.33	0.45	0.60	0.92								
+/- 0.5	12	0.19	0.28	0.40	0.54	0.71	1.11	1.60							
	14	0.22	0.33	0.47	0.63	0.83	1.29	1.87							
	16	0.25	0.37	0.53	0.72	0.95	1.48	2.14	3.79						
	18	0.28	0.42	0.60	0.81	1.07	1.66	2.40	4.26						
	20	0.31	0.47	0.67	0.89	1.19	1.85	2.67	4.73	7.5					
	22	0.34	0.51	0.73	0.98	1.31	2.03	2.94	5.21	8.3					
	24	0.37	0.56	0.80	1.07	1.43	2.22	3.20	5.68	9.0	13.0				
	26	0.41	0.61	0.87	1.16	1.55	2.40	3.47	6.15	9.8	14.1				
	28	0.44	0.66	0.93	1.25	1.67	2.58	3.74	6.63	10.5	15.2	20.5			
	30	0.47	0.70	1.00	1.34	1.79	2.77	4.00	7.10	11.3	16.2	22.0			
	32	0.50	0.75	1.07	1.43	1.91	2.95	4.27	7.57	12.0	17.3	23.4	30.1		
	35	0.55	0.82	1.17	1.57	2.09	3.23	4.67	8.28	13.2	19.0	25.6	32.9		
	40	0.62	0.94	1.33	1.79	2.38	3.69	5.34	9.47	15.0	21.7	29.3	37.6		
	45		1.05	1.50	2.01	2.68	4.15	6.01	10.65	16.9	24.4	33.9	42.3	66.0	
	50			1.67	2.24	2.98	4.62	6.67	11.83	18.8	27.1	36.6	47.0	73.4	
+/- 0.75	55					3.28	5.08	7.34	13.02	20.7	29.8	40.2	51.7	80.7	
	60					3.57	5.54	8.01	14.20	22.6	32.5	43.9	56.4	88.0	
	65							8.67	15.38	24.4	35.2	47.6	61.1	95.4	
	70							9.34	16.57	26.3	37.9	51.2	65.8	102.7	
	75							10.01	17.75	28.2	40.6	54.9	70.5	110.0	
	80								18.93	30.1	43.3	58.5	75.2	117.4	
	85								20.12	31.9	46.0	62.2	79.9	124.7	
	90								21.30	33.8	48.7	65.9	84.6	132.0	
	95								22.48	35.7	51.5	69.5	89.3	139.4	
	100								23.67	37.6	54.2	73.2	94.0	146.7	
	120								28.40	45.1	65.0	87.8	112.8	176.0	
	140										75.8	102.4	131.6	205.4	
	160										86.7	117.1	150.3	234.7	
	180											131.7	169.1	264.1	
	200											146.4	187.9	293.4	

Deviation allowed length l⁵⁾

Weight (7.85 kg/dm³) kg/per 1000 ≈

Coiled spring pins DIN EN ISO 8748 (heavy duty)

Designation of a coiled spring pin with 10 mm nominal diameter and length $l = 40$ mm in heavy duty, made from steel:

DIN EN ISO 8748
spring pin – 10 x 40 – ST

- 1) The nominal diameter of the spring pin is identical to the nominal diameter of the corresponding seating hole, for which tolerance field H 12 is specified.
- 2) Each individual case must be examined to determine whether, on the basis of physical circumstances, these shear forces need to be taken into account. The examination of the shear force will be according to DIN EN ISO 8749.
- 3) Only valid for coiled spring pins made from steel.
- 4) Only valid for coiled spring pins made from stainless steel.
- 5) Coiled spring pins made from stainless steel can only be produced up to max. 50 mm length.

Nominal diameter ¹⁾		2	2,5	3	3,5	4	5	6	8	10	12	14	16	20	
DIN EN ISO 8748	Before installation	d_1 min.	2.11	2.62	3.12	3.64	4.15	5.15	6.18	8.25	10.30	12.35	14.40	16.40	20.40
		d_1 max.	2.21	2.73	3.25	3.79	4.30	5.35	6.40	8.55	10.65	12.75	14.85	16.90	21.00
		d_2 max.	1.90	2.40	2.90	3.40	3.90	4.85	5.85	7.80	9.75	11.70	13.60	15.60	19.60
		$a \approx$	0.70	0.70	0.90	1.00	1.10	1.30	1.50	2.00	2.50	3.00	3.50	4.00	4.50
		s	0.22	0.28	0.33	0.39	0.45	0.56	0.67	0.90	1.10	1.30	1.60	1.80	2.20
Shear force ²⁾ double-shear		kN	3.50	5.50	7.60	10	13.5	20	30	53	84	120	165	210	340
+/- 0.25	4	0.08													
	5	0.09	0.14												
	6	0.11	0.17	0.25	0.34										
	8	0.15	0.23	0.33	0.45	0.59									
	10	0.19	0.29	0.41	0.57	0.74	1.14								
+/- 0.5	12	0.23	0.34	0.50	0.68	0.89	1.37	1.63							
	14	0.27	0.40	0.58	0.79	1.04	1.60	1.96							
	16	0.30	0.46	0.66	0.91	1.19	1.83	2.61	4.75						
	18	0.34	0.51	0.75	1.02	1.34	2.06	2.93	5.34						
	20	0.38	0.57	0.83	1.13	1.48	2.29	3.26	5.93	9.3					
	22	0.42	0.63	0.91	1.25	1.63	2.51	3.59	6.53	10.3					
	24	0.46	0.69	0.99	1.36	1.78	2.74	3.91	7.12	11.2	16.0				
	26	0.49	0.74	1.08	1.47	1.93	2.97	4.24	7.71	12.1	17.4				
	28	0.53	0.80	1.16	1.59	2.08	3.20	4.57	8.31	13.1	18.7	25.4			
	30	0.57	0.86	1.24	1.70	2.23	3.43	4.89	8.90	14.0	20.0	27.2			
	32	0.61	0.91	1.33	1.81	2.37	3.66	5.22	9.50	14.9	21.4	29.0	36.8		
	35	0.66	1.00	1.45	1.98	2.60	4.00	5.71	10.39	16.3	23.4	31.7	40.3		
	40	0.76	1.14	1.66	2.27	2.97	4.57	6.52	11.87	18.7	26.7	36.2	46.0		
	45		1.29	1.87	2.25	3.34	5.14	7.34	13.35	21.0	30.1	40.8	51.8	83.4	
	50			2.07	2.83	3.71	5.71	8.15	14.84	23.3	33.4	45.3	57.6	92.7	
+/- 0.75	55					4.08	6.29	8.97	16.32	25.6	36.8	49.8	63.3	102.0	
	60					4.45	6.86	9.78	17.80	28.0	40.1	54.4	69.1	111.2	
	65							10.60	19.29	30.3	43.4	58.9	74.8	120.5	
	70							11.41	20.77	32.6	46.8	63.4	80.6	129.8	
	75							12.23	22.25	35.0	50.1	68.0	86.3	139.1	
	80								23.74	37.3	53.5	72.5	92.1	148.3	
	85								25.22	39.6	56.8	77.0	97.8	157.6	
	90								26.71	42.0	60.1	81.6	103.6	166.9	
	95								28.19	44.3	63.5	86.1	109.3	176.1	
	100								29.67	46.6	66.8	90.6	115.1	185.4	
	120								35.61	56.0	80.2	108.7	138.1	222.5	
	140										93.5	126.9	161.1	259.6	
	160										106.9	145.0	184.2	296.6	
	180											163.1	207.2	333.7	
	200											181.2	230.2	370.8	

Deviation allowed length l ⁵⁾

Weight (7.85 kg/dm³) kg/per 1000 ≈

Tension pins



DIN EN ISO 8752
50 x 180 mm



DIN EN ISO 8752
4 x 16 mm



DIN EN ISO 13337
5 x 30 mm

DIN EN ISO 8752
20 x 45 mm

DIN EN ISO 13337
50 x 140 mm



Special execution
with flared head and
interlocking device



DIN EN ISO 8752
with toothed slot
(non-interlocking)

Coiled Spring Pins



DIN EN ISO 8750
10 x 100 mm



DIN EN ISO 8748
16 x 40 mm



DIN EN ISO 8750
8 x 80 mm



DIN EN ISO 8748
16 x 42 mm

Jörg Vogelsang is one of the world's leading manufacturers of formed metal parts. Our precision products made from steel and non-ferrous metal are of the highest quality.

Jörg Vogelsang, together with Vogelsang Corp., USA, is the largest producer of spring pins, tension bushes and rolled bushes in the world.

Manufacturing Program

- Tension Pins
- Coiled Spring Pins
- Tension Bushes
- Chassis Components
- Safety Belt Components
- compression limiter®

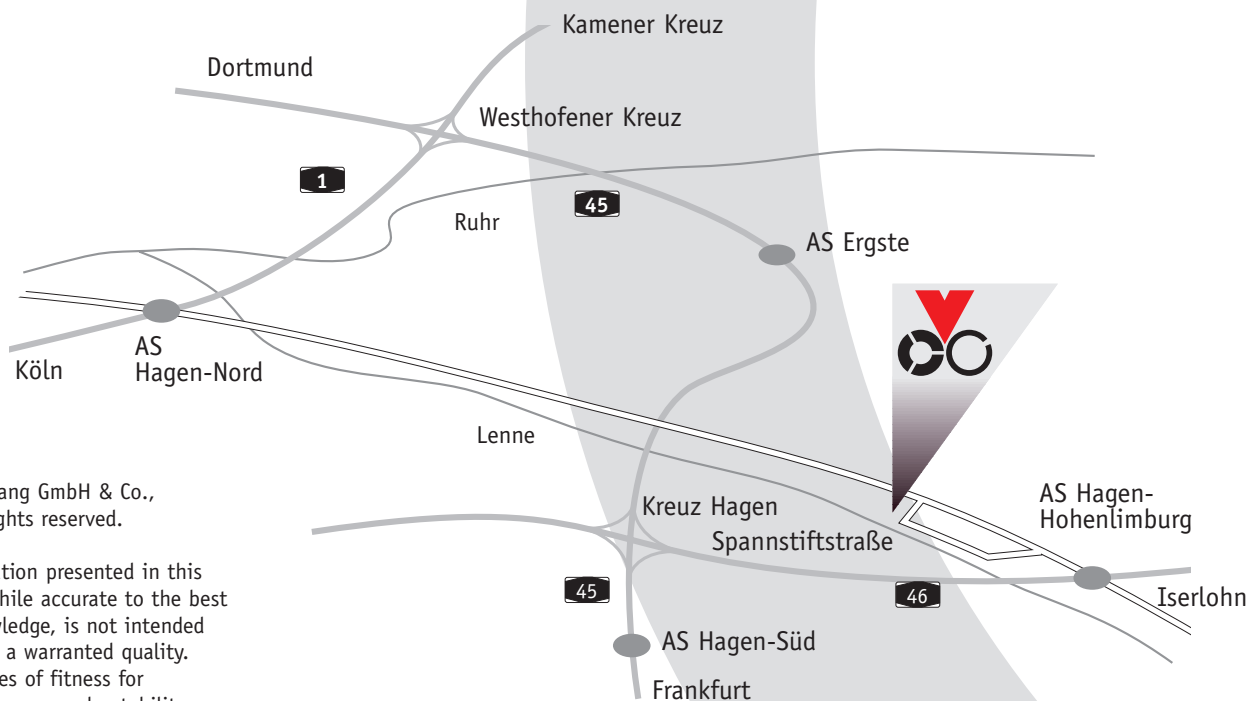

Copyright
Jörg Vogelsang GmbH & Co.,
2003, all rights reserved.

The information presented in this brochure, while accurate to the best of our knowledge, is not intended to set forth a warranted quality. No warranties of fitness for intended use or merchantability are given or implied. Therefore, liability for damages of any kind is expressly excluded.

Jörg Vogelsang GmbH & Co.
Postfach 53 26, D-58103 Hagen
Spannstiftstraße 2, D-58119 Hagen
Phone +49 (0) 23 34/957-0
Fax +49 (0) 23 34/957-269
E-Mail: Info@jvu.de
Internet: www.jvu.de