

# Components



# Roll-Ring® Self Adjusting Chain Tensioner

Roll-Ring® is a simple yet innovative chain tensioner made from a specially formulated polymer.

The unique design is based upon a simple toothed ring that can be fitted to horizontal, vertical, or diagonal drives in a matter of seconds, simply by placing it in-between the two strands of chain. When the drive is in use, Roll-Ring® deforms to an elliptical shape due to compression between the strands and completely absorbs any slack in the system. Roll-Ring® performs the job of a tensioner and a damper in one, and is ideally suited to applications where maintenance is difficult or impossible.

## Technical Details

Roll-Ring® chain tensioners provide tensioning using:

- Static tensioning force from the elastic ring
- Dynamic tensioning force from the damping of the working material

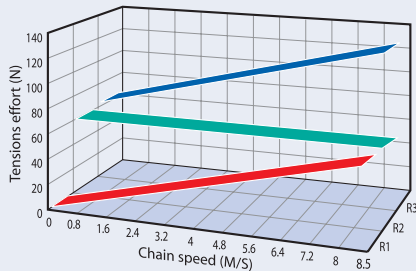

Tensioning effort for ROLL-RING®: Dynamic force R1 (red), Static force R2 (green), Resultant force R3 (blue)

Roll-Ring® provides as much tensioning as possible at low chain speeds, and has reserves of tensioning and damping capability for higher chain speeds. The above diagram shows the tensioning force of a Roll-Ring® chain tensioner with individual allocations of tensioning force and their resulting effects.

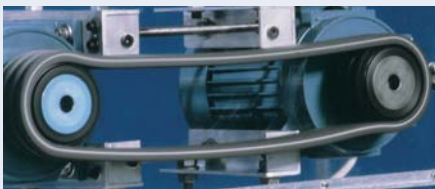

Vibrations in an untensioned chain drive

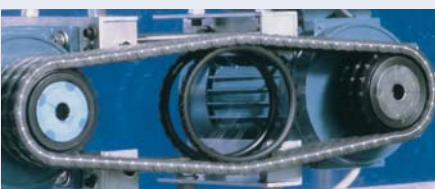

The Roll-Ring® chain tensioner tensions and dampens

## Benefits

The Roll-Ring® chain tensioner provides cost effective, time-saving installation and maintenance.

The advantages over other types of chain tensioners are:

- Free standing—no sprockets, bolts, plates, drilling, or costly installation required.
- Roll-Ring® is easily installed where space limitations prohibit the use of conventional chain tensioners.
- Roll-Ring® is fitted in a matter of seconds.
- Roll-Ring® is ready for use without any tools, tensioning equipment, or further alignment or adjustment.
- Roll-Ring® is fully effective in vertical and diagonal drives.
- Roll-Ring® works automatically and is maintenance free and self lubricating.
- Roll-Ring® can be used in dusty and dirty environments.
- Roll-Ring® is a tensioner and damper in one, thus reducing noise levels.
- Roll-Ring® also works in reverse mode.

Roll-Ring® chain tensioners reduce chain wear and improve the quality and efficiency of the complete chain drive.



Snap-in installation

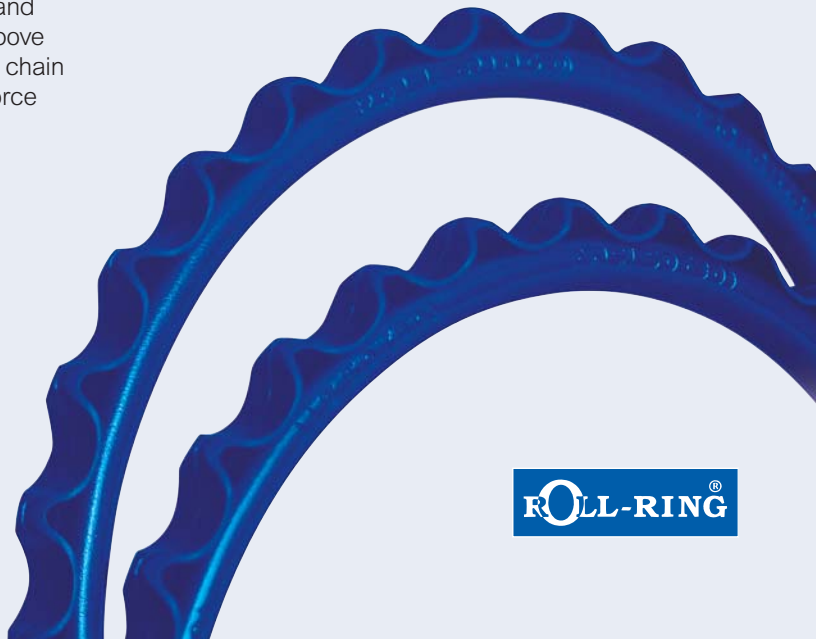

The Roll-Ring® chain tensioner is based on two simple phenomena:

- The elastic ring engages with the chain drive strands and rolls between them in a pre-stressed condition, taking the shape of an ellipse.
- The constantly opposing movements of the load and slack strands cancel each other out, thereby holding the Roll-Ring® in position.

### Installation and maintenance

Roll-Ring® chain tensioners are maintenance free and can be fitted to a wide variety of chain drives with no installation downtime.

Requirements:

- A working space with a gap between the chain strands which is smaller than the reference diameter of the chain tensioner.
- A sufficient gap between the chain drive sprockets.

It is recommended that Roll-Ring® be positioned between two chain strands such that there is at least one chain pitch between the Roll-Ring® and the smallest sprocket. The Roll-Ring® can also be positioned just as effectively outside this recommended area, as long as it is sufficiently pre-stressed. In this case, practical trial and error testing is recommended.

Roll-Ring® chain tensioners can be used in line within the same chain strand, or parallel with each other in multi-strand chain drives. Triple-strand chain drives require only two Roll-Ring® positioned on the outer strands.

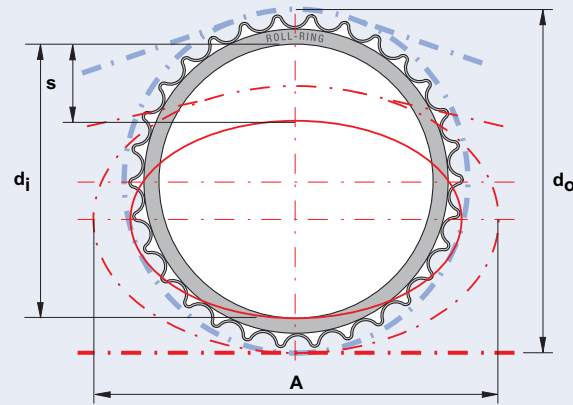

## Roll-Ring® Chain Tensioners Standard Product Range

Part Number	Teeth	Chain Number	do	di	s	A
10503001	30	05B	3.014	2.561	0.788	4.098
10603001	30	35	3.589	2.876	0.985	4.807
10603601	36	35	4.295	3.526	0.985	5.634
10802601	26	40	4.023	3.329	0.946	5.351
10803001	30	40	4.787	3.861	1.103	6.367
10803401	34	40	5.418	4.547	1.182	6.501
11002601	26	50	5.059	4.137	1.103	6.028
11003001	30	50	5.831	4.909	1.300	6.974
11003401	34	50	6.698	5.555	1.497	8.550
11202601	26	60	6.107	5.027	1.379	8.254
11203001	30	60	7.179	5.713	1.576	9.523
11203401	34	60	8.176	6.678	1.773	10.441
11602601	26	80	8.156	6.580	1.773	10.599
11603001	30	80	9.685	7.959	1.970	12.056
12003001	30	100	11.966	9.614	2.364	15.366

# Rivet Extractors

## Rivet Extractors for Chain Breaking

Screw-operated extractors break chain by forcing Renold's end-softened bearing pins out of the outer link plates. Other brands of chain require that the rivet swell must first be ground away.

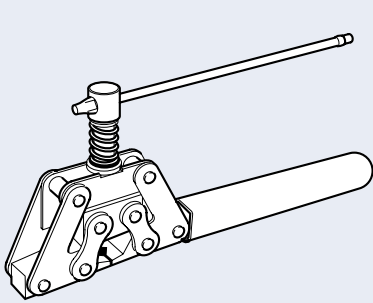

Part No. 10101  
For use with chains:  
0.375" to 0.625"  
ANSI and BS Series

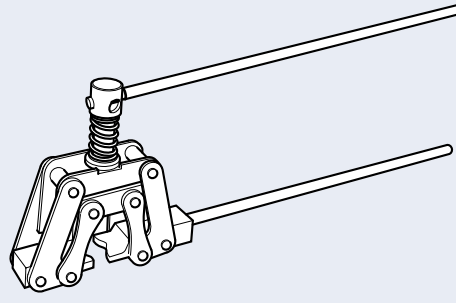

Part No. 10102  
For use with chains:  
0.75" to 1" ANSI Series  
0.75" to 1.25" BS Series

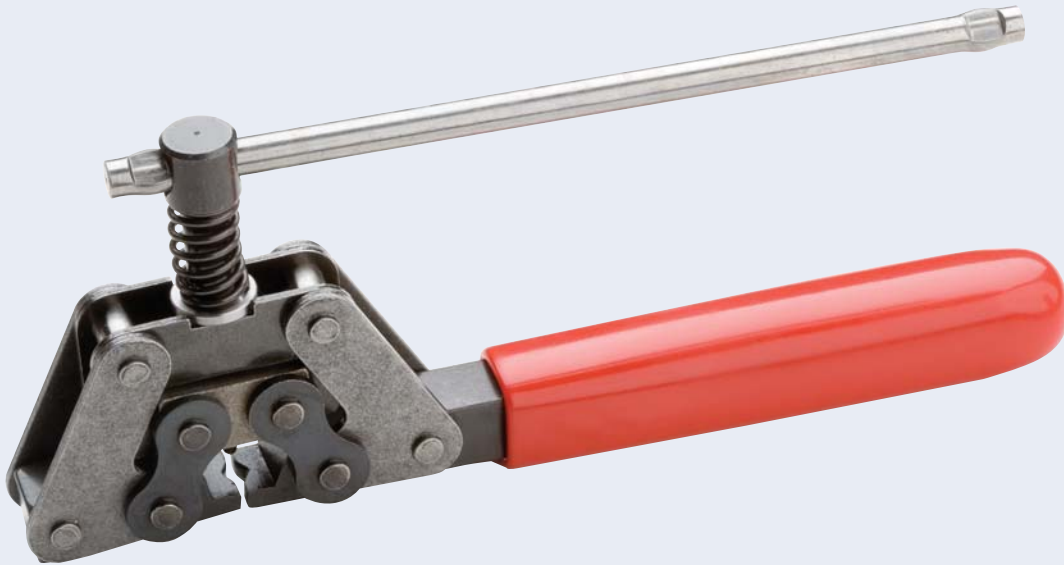

Part Number	Pitch	
	ANSI	British Standard
10101	.375 to .625	.375 to .625
10102	0.75 to 1.00	0.75 to 1.25
311502	1.25 to 2.00	1.25 to 2.00
311503	2.00 to 4.00	2.00 to 4.00